

Article number: 03 038 00 99

WC module MONTUS Flow Type C 120

WC module, height 115 cm with concealed cistern 12 cm. For stud wall or pre-wall mounting or exposed installation. Suitable for networking with the SCHELL SWS water management system. Configurable via SCHELL Single Control SSC. Integrated flush valve with drain via flush pipe for scheduled stagnation flushes. For wall-mounted WC with 180 or 230 mm fastening dimension. Self-supporting, powder-coated steel profiled frame with height-adjustable feet. Saves water with dual flush and delayed filling process (saves about 0.5 l/flush). Flush triggering electronic or mechanical.

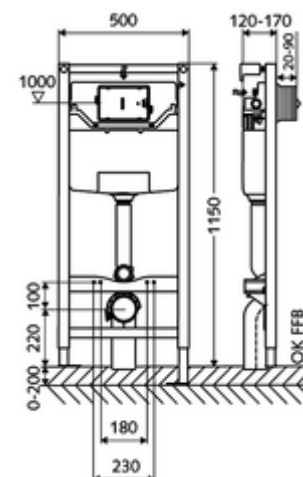

Scope of delivery

- WC module
 - WC concealed cistern 12 cm, actuation from front
 - Angle valve with regulating function, G 1/2 AG, noise class I
 - Flush pipe Ø 45 mm, with construction plug
 - Galvanised, height-adjustable mounting feet 0 - 20 cm with slip resistance
- Reducer Ø 90 / 110 mm
- WC connection set (supply Ø 45 mm, drain Ø 90/110 mm)
- Conduit 5 m
- 5 m extension cable
- Fastening material for WC installation (fastening bolts M 12 x 200 mm, protection hoses, plastic collar bushings, nuts, flat washers, cover caps)
- Fastening material for installation feet

Technical data

- Material: Angle valve Brass, conform to German drinking water regulations; Frame Steel
- Dual flush: Eco flush volume 3 l, Main flush volume 4/5/6/7 l adjustable (6 l factory setting)
- Load capacity: max. 400 kg (when using MONTUS wall bracket set)
- Surface: Frame Powder coat finish
- Dimensions: w 50 cm x h 115 cm
- Waste water connection: Ø 90 /110 mm
- Flush pipe connection: Ø 45 mm
- Water connection: DN 15 R 1/2 AG (rear centre)
- Waste water outlet: Ø 90/110 mm

Delivery data

- Weight: 13,04 kg/Piece
- Packing unit: 1

Necessary associated articles

For exposed installation

MONTUS wall bracket set (120 - 170 mm)

Article no: 03 071 00 99 or

MONTUS wall bracket set (150 - 210 mm)

Article no: 03 077 00 99 or

For mechanical actuation

WC operating panel MONTUS CIRCUM

Article no: 03 119 64 99 or

WC operating panel MONTUS CIRCUM

Article no: 03 119 06 99 or

WC operating panel MONTUS CIRCUM	Article no: 03 119 15 99 or
WC operating panel MONTUS BOARD	Article no: 03 120 06 99 or
WC operating panel MONTUS BOARD	Article no: 03 120 64 99 or
WC operating panel MONTUS BOARD	Article no: 03 120 15 99 or
WC operating panel MONTUS TOWER	Article no: 03 121 06 99 or
WC operating panel MONTUS TOWER	Article no: 03 121 64 99 or
WC operating panel MONTUS TOWER	Article no: 03 121 15 99 or
WC operating panel MONTUS KONKAV	Article no: 03 122 64 99 or
WC operating panel MONTUS KONKAV	Article no: 03 122 06 99 or
WC operating panel MONTUS KONKAV	Article no: 03 122 15 99 or
WC operating panel MONTUS PLACE	Article no: 03 070 28 99 or
WC operating panel MONTUS FIELD	Article no: 03 126 06 99 or

For electronic actuation

Electronic conversion kit MONTUS	Article no: 03 127 00 99
WC operating panel MONTUS FIELD E	Article no: 03 123 06 99 or
WC operating panel MONTUS FIELD H	Article no: 03 124 06 99 or

For networking with SWS water management system

SWS Server	Article no: 00 500 00 99
SWS Bus mains adapter	Article no: 00 505 00 99
SWS Bus Extender wired BE-K Flow	Article no: 00 563 00 99 and/or
SWS Bus Extender wireless BE-F Flow	Article no: 00 564 00 99 and/or

For operation with Single Control SSC

SSC Bluetooth® module Flow	Article no: 00 929 00 99
----------------------------	--------------------------

For operation with SWS BE-F wireless bus extender or Single Control SSC

Top-hat rail transformer 9 VDC, 100 - 240 VAC, 50 - 60 Hz	Article no: 01 582 00 99 or
Electrical junction box 9 VDC, 100 - 240 VAC, 50 - 60 Hz	Article no: 01 583 00 99 or

Recommended associated articles

Concealed junction box MONTUS FLOW	Article no: 77 752 00 99
SWS Temperature sensor PT 1000	Article no: 00 562 00 99