

Article number: 03 047 00 99

## WC module MONTUS Type C-N 80 - 2/4 I

WC module with concealed cistern 8 cm. For expansion, installation and conversion work in masonry. For wall-mounted WC with 180 or 230 mm fastening dimension. U-shaped, non-self-supporting, galvanised steel frame. Saves water with dual flush and delayed filling process (saves about 0.5 l/flush).

### Scope of delivery

- WC module
  - WC concealed cistern 8 cm, actuation from front
  - Angle valve with regulating function, G 1/2 AG, noise class I
  - Flush pipe  $\varnothing$  45 mm, with construction plug
- Reducer  $\varnothing$  90 / 110 mm
- WC connection set (supply  $\varnothing$  45 mm, drain  $\varnothing$  90/110 mm)
- PP drain elbow  $\varnothing$  90/90 mm, with construction plug
- Fastening material for WC installation (fastening bolts M 12 x 200 mm, protection hoses, plastic collar bushings, nuts, flat washers, cover caps)
- Plaster base mat
- Fastening material for wall installation

### Technical data

- Material: Frame Steel
- Surface: Frame Galvanised
- Dimensions: w 46 cm x h 78 cm
- Waste water connection:  $\varnothing$  90 /110 mm
- Flush pipe connection:  $\varnothing$  45 mm
- Water connection: DN 15 R 1/2 AG (top)
- Waste water outlet:  $\varnothing$  90/110 mm
- Certificates: SASO

### Delivery data

- Weight: 6,90 kg/Piece
- Packing unit: 1

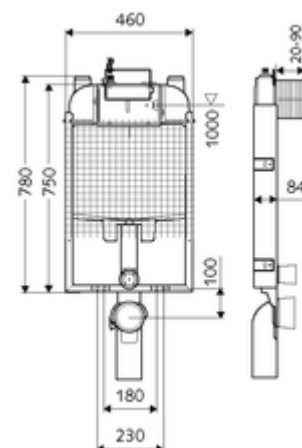

### Necessary associated articles

WC sound-insulation mat	Article no: 03 001 00 99
<u>For mechanical actuation</u>	
WC operating panel MONTUS CIRCUM	Article no: 03 119 15 99
WC operating panel MONTUS CIRCUM	Article no: 03 119 64 99
WC operating panel MONTUS CIRCUM	Article no: 03 119 06 99
WC operating panel MONTUS BOARD	Article no: 03 120 06 99
WC operating panel MONTUS BOARD	Article no: 03 120 15 99
WC operating panel MONTUS BOARD	Article no: 03 120 64 99
WC operating panel MONTUS TOWER	Article no: 03 121 64 99
WC operating panel MONTUS TOWER	Article no: 03 121 15 99
WC operating panel MONTUS TOWER	Article no: 03 121 06 99
WC operating panel MONTUS KONKAV	Article no: 03 122 06 99
WC operating panel MONTUS KONKAV	Article no: 03 122 64 99
WC operating panel MONTUS KONKAV	Article no: 03 122 15 99

WC operating panel MONTUS PLACE	Article no: 03 070 28 99
WC operating panel MONTUS FIELD	Article no: 03 126 06 99
WC operating panel MONTUS FIELD	Article no: 03 126 64 99
<u>For electronic actuation</u>	
Electronic conversion kit MONTUS	Article no: 03 125 00 99
WC operating panel MONTUS FIELD E	Article no: 03 123 06 99
WC operating panel MONTUS FIELD H	Article no: 03 124 06 99