

Article number: 03 061 00 99

WC module MONTUS Type C 90

WC module, height 115 cm with concealed cistern 8 cm. For flat stud partition/exposed installation. For wall-mounted WC with 180 or 230 mm fastening dimension. Self-supporting, powder-coated steel profiled frame with height-adjustable feet. Saves water with dual flush and delayed filling process (saves about 0.5 l/flush).

Scope of delivery

- WC module
 - WC concealed cistern 8 cm, actuation from front
 - Angle valve with regulating function, G 1/2 AG, noise class I
 - Flush pipe Ø 45 mm, with construction plug
 - Height-adjustable installation feet 0-15 cm
- Reducer Ø 90 / 110 mm
- WC connection set (supply Ø 45 mm, drain Ø 90/110 mm)
- PP drain elbow Ø 90/90 mm, with construction plug
- Fastening material for WC installation (fastening bolts M 12 x 200 mm, protection hoses, plastic collar bushings, nuts, flat washers, cover caps)
- Fastening material for installation feet

Technical data

- Dual flush: Eco flush volume 3 l, Main flush volume 6/7 l adjustable (6 l factory setting)
- Material: Frame Steel
- Surface: Frame Powder coat finish
- Dimensions: w 50 cm x h 115 cm
- Waste water connection: Ø 90 /110 mm
- Flush pipe connection: Ø 45 mm
- Water connection: DN 15 R 1/2 AG (top)
- Waste water outlet: Ø 90/110 mm
- Certificates: Belgaqua

Delivery data

- Weight: 13,52 kg/Piece
- Packing unit: 1

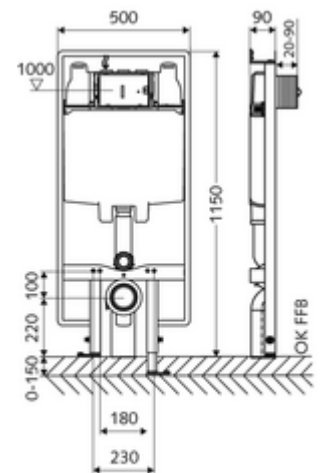

Necessary associated articles

WC sound-insulation mat	Article no: 03 001 00 99	
<u>For mechanical actuation</u>		
WC operating panel MONTUS CIRCUM	Article no: 03 119 06 99	or
WC operating panel MONTUS CIRCUM	Article no: 03 119 64 99	or
WC operating panel MONTUS CIRCUM	Article no: 03 119 15 99	or
WC operating panel MONTUS BOARD	Article no: 03 120 64 99	or
WC operating panel MONTUS BOARD	Article no: 03 120 06 99	or
WC operating panel MONTUS BOARD	Article no: 03 120 15 99	or
WC operating panel MONTUS TOWER	Article no: 03 121 64 99	or
WC operating panel MONTUS TOWER	Article no: 03 121 06 99	or
WC operating panel MONTUS TOWER	Article no: 03 121 15 99	or

WC operating panel MONTUS KONKAV	Article no: 03 122 06 99	or
WC operating panel MONTUS KONKAV	Article no: 03 122 64 99	or
WC operating panel MONTUS KONKAV	Article no: 03 122 15 99	or
WC operating panel MONTUS PLACE	Article no: 03 070 28 99	or
WC operating panel MONTUS FIELD	Article no: 03 126 06 99	or
WC operating panel MONTUS FIELD	Article no: 03 126 64 99	or
<u>For electronic actuation</u>		
Electronic conversion kit MONTUS	Article no: 03 125 00 99	
WC operating panel MONTUS FIELD E	Article no: 03 123 06 99	or
WC operating panel MONTUS FIELD H	Article no: 03 124 06 99	or

Hint

- When using support or support folding handles for barrier-free WCs, combine with MONTUS type CS 120 WC module (width: 42 cm).