

Article number: 03 089 00 99

Urinal module MONTUS Type COMPACT II LC

Urinal module, height 115 cm with concealed COMPACT II flush valve. For stud wall or pre-wall mounting or exposed installation. Self-supporting, powder-coated steel profiled frame with height-adjustable feet and cross bars. Flush triggering via COMPACT LC urinal control.

Scope of delivery

- Urinal module
 - Cross bar with concealed COMPACT II flush valve, with isolating valve and flush-mounted cap, height-adjustable, intended for COMPACT LC urinal control
 - Cross bar with drain elbow and construction plug, height-adjustable
 - Cross bar for urinal attachment 40-375 mm, height-adjustable
 - Cross bar with noise-insulated urinal connection, with construction plug, height-adjustable
 - Flexible hose
 - Galvanised, height-adjustable mounting feet 0 - 20 cm with slip resistance
- Fastening material for urinal installation (fastening bolts M 8 x 100 mm, protection hose, plastic collar bushings, nuts, flat washers, cover caps)
- Fastening material for installation feet

Technical data

- Flow pressure: 0.8 - 5.0 bar
- Flush flow: 0.3 l/s
- Material: Frame Steel; Waterpath Dezincification-resistant brass, conform to German drinking water regulations
- Surface: Frame Powder coat finish
- Dimensions: w 50 cm x h 124 cm
- Waste water connection: Ø 50 mm
- Water connection: DN 15 G 1/2 AG (right)
- Waste water outlet: Ø 50 mm
- Water outlet: DN 15 G 1/2 IG

Delivery data

- Weight: 12,00 kg/Piece
- Packing unit: 1

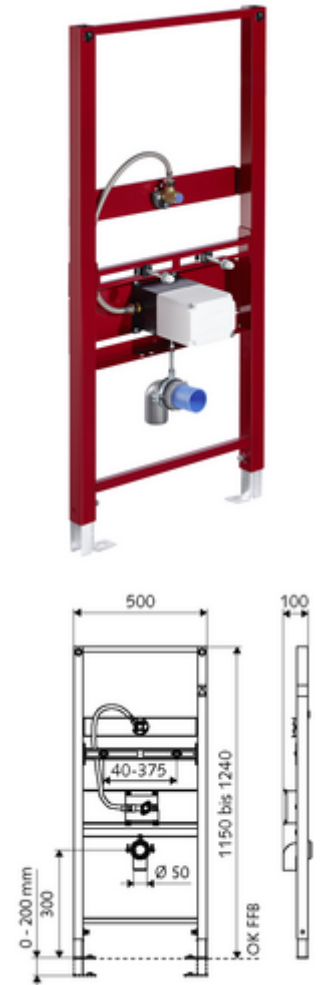

Necessary associated articles

Urinal inlet connection DN 15	Article no: 03 105 00 99	
<u>For exposed installation</u>		
MONTUS wall bracket set (120 - 170 mm)	Article no: 03 071 00 99	or
MONTUS wall bracket set (150 - 210 mm)	Article no: 03 077 00 99	or
<u>Urinal controls</u>		
Urinal control COMPACT LC	Article no: 01 196 00 99	or
Urinal control COMPACT LC	Article no: 01 197 00 99	or