

Article number: 02 179 06 99

Electronic wash basin tap MODUS E HD-M - high-pressure mixed water

Infrared sensor-controlled. Battery or mains operation.

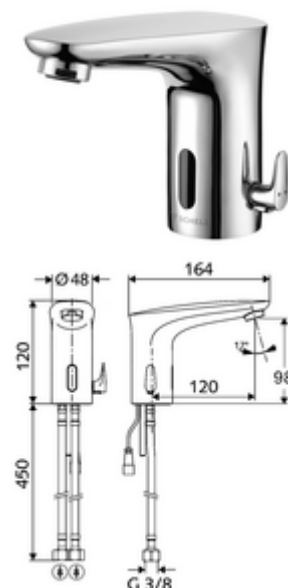

Scope of delivery

- Infrared sensor single-hole tap
 - Temperature controller with hot water restrictor
 - Infrared sensor electronics, programmable
 - 6 V solenoid valve with pre-filter
 - Flow regulator
 - Connection cable, 200 mm, with 2-pin plug, protection class IP65
 - 2 flexible connection hoses, G 3/8 IG x 450 mm, with backflow preventer (DIN EN 1717: EB-type) and pre-filter
- Transformer plug 6 VDC, 100-240 VAC, 50-60 Hz
- Fastening material for wash basin installation

Technical data

- Setting options via short range reflex
 - Sensor range area (approx. 2-17 cm)
 - Stagnation flush (off/duration of flow 30 s, 24 h after last use)
 - Cleaning stop (off/120 s)
- Flow: max. 3 l/min pressure independent
- Flow pressure: 0.5 - 5.0 bar
- Max. Resting pressure: 8 bar
- Max. operating temperature: 70 °C (temporarily, e.g. for thermal disinfection)
- Material: DZR brass
- Surface: Chrome
- Connection: 2x G 1/2 IG
- Certificates: dr, Watermark, WELS

Delivery data

- Weight: 1,78 kg/Piece
- Packing unit: 1

Recommended associated articles

Angle valve thermostat	Article no: 09 414 06 99
Pressure balance valve (PBV)	Article no: 06 558 12 99
Angle valve with regulating function COMFORT with filter	Article no: 05 430 06 99
Flow regulator set LEED 1.3 I	Article no: 28 931 06 99 or
Wash basin outlet valve OPEN	Article no: 02 002 06 99 or
Wash basin outlet valve PUSH OPEN	Article no: 02 000 06 99 or