

Article number: 02 181 06 99

Wash basin tap MODUS EH HD-M - high-pressure mixed water

Compact single-lever mixer tap with lever.



Scope of delivery

- Single-lever single-hole tap
 - Single-lever mixer
 - Single-lever mixer ceramic cartridge with adjustable hot water and flow limitation
 - Aerator
- 2 flexible Clean-Fix S connection hoses, G 3/8 IG x 440 mm, with integrated backflow preventer (EN 1717: EB-type) and pre-filter
- Fastening material for wash basin installation

Technical data

- Flow: max. 5 l/min pressure independent
- Flow pressure: 1.0 - 5.0 bar
- Max. Resting pressure: 8 bar
- Max. operating temperature: 70 °C (80 °C for thermal disinfection)
- Material: Actuation Die-cast zinc; Housing Brass, conform to German drinking water regulations
- Surface: Chrome
- Connection: 2x G 3/8 IG
- Certificates: P-IX 29002/IO, DIN-DVGW, Belgaqua
- Noise class: I
- Flow class: O

Delivery data

- Weight: 1,74 kg/Piece
- Packing unit: 1

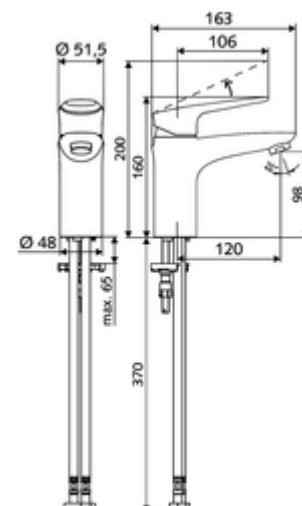

Recommended associated articles

Flow regulator set LEED 1.3 l	Article no: 28 931 06 99 or
Flow regulator set 3.0 l/min pressure-independent	Article no: 28 932 06 99 or
Flow regulator max. 5.7 l/min pressure-independent, theft-proof	Article no: 02 121 06 99 or
Angle valve thermostat	Article no: 09 414 06 99
Wash basin outlet valve OPEN	Article no: 02 002 06 99 or
Wash basin outlet valve PUSH OPEN	Article no: 02 000 06 99 or