

Article number: 00 223 06 99

Electronic wash basin tap XERIS E HD-M large - high-pressure mixed water

Infrared sensor-controlled. Excluding power supply. Suitable for networking with the SCHELL SWS water management system. Configurable via SCHELL Single Control SSC. Intended for power supply via SCHELL water management system SWS or central power supply unit.

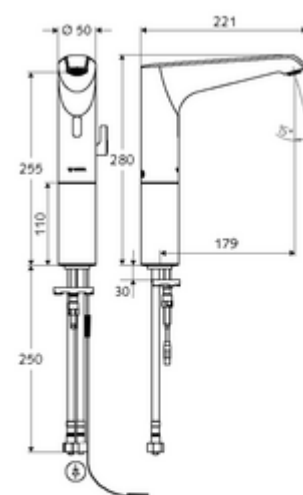

Scope of delivery

- Infrared sensor single-hole tap
 - Temperature controller
 - Infrared sensor electronics, programmable
 - Standpipe extension
 - 6 V axial solenoid valve with pre-filter
 - Flow regulator
 - Connection cable, 350 mm, with 3-pin plug connector, protection class IP65
- 2 flexible Clean-Fix S connection hoses, G 3/8 IG x 500 mm, with integrated backflow preventer (EN 1717: EB-type) and pre-filter
- Fastening material for wash basin installation

Technical data

- Setting options via SWS SSC
 - Sensor range (short/medium/long)
 - Programming via short range reflex (off/on)
 - Max. flow time (1-360 s)
 - Follow-up time (0.6-60 s)
 - Stagnation flush (off/5-600 s, every 1-240 h after last flush/every 1-240 h)
 - Continuous flush for thermal disinfection, with anti-scalding protection (off/15-600 s)
 - Duration of flow (off/15-600 s)
 - Energy saving mode (off/1-254 h after last flush)
 - Cleaning stop (off/60-360 s)
- Setting options via short range reflex
 - Sensor range (short/medium/long)
 - Stagnation flush (off/30 s, every 24 h after last flush/every 24 h)
 - Continuous flush for thermal disinfection, with anti-scalding protection (off/300 s/120 s)
 - Cleaning stop (off/60 s)
- Flow: max. 5 l/min pressure independent
- Flow pressure: 1.0 - 5.0 bar
- Max. Resting pressure: 8 bar
- Max. operating temperature: 70 °C (80 °C for thermal disinfection)
- Material: Housing Brass; Parts in contact with water Plastic
- Surface: Chrome
- Connection: 2x G 3/8 IG
- Certificates: PA-IX 29072/IO, Belgaqua
- Noise class: I
- Flow class: O

Delivery data

- Weight: 2,37 kg/Piece
- Packing unit: 1

Necessary associated articles

SWS Server	Article no: 00 500 00 99
SWS Bus mains adapter	Article no: 00 505 00 99
SWS Bus extender cable BE-K	Article no: 00 501 00 99

Recommended associated articles

Angle valve thermostat	Article no: 09 414 06 99
Angle valve with regulating function COMFORT with filter	Article no: 05 430 06 99

Optional power supply via collective mains adapter

Concealed power supply unit 9 VDC, 100 - 240 VAC, 50 - 60 Hz	Article no: 01 315 00 99 or
Top-hat rail transformer 9 VDC, 100 - 240 VAC, 50 - 60 Hz	Article no: 01 582 00 99 or
Electrical junction box 9 VDC, 100 - 240 VAC, 50 - 60 Hz	Article no: 01 583 00 99 or