

Article number: 00 234 06 99

## Electronic wash basin tap XERIS E-T HD-M mid - high-pressure mixed water, ThermoProtect thermostat

Infrared sensor-controlled. Mains operation (concealed transformer). Suitable for networking with the SCHELL SWS water management system. Configurable via SCHELL Single Control SSC.

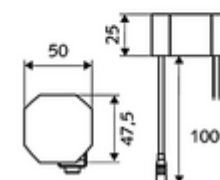
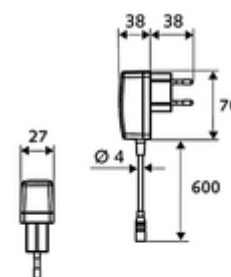
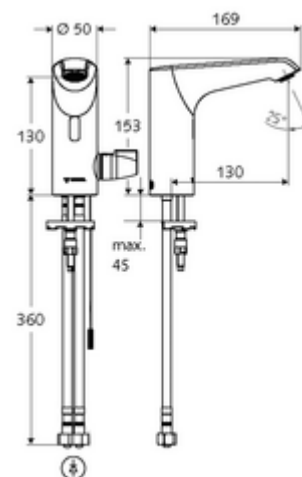

### Scope of delivery

- Infrared sensor single-hole tap
  - ThermoProtect thermostat, conform to EN 1111, temperature lock (factory setting 38 °C), anti-scalding protection if cold water supply fails
  - Infrared sensor electronics, programmable
  - 6 V axial solenoid valve with pre-filter
  - Flow regulator
  - Connection cable, 220 mm, with 3-pin plug connector, protection class IP65
- Concealed transformer 9 VDC, 100-240 VAC, 50-60 Hz
- 2 flexible Clean-Fix S connection hoses, G 3/8 IG x 400 mm, with integrated backflow preventer (EN 1717: EB-type) and pre-filter
- Fastening material for wash basin installation

### Technical data

- Setting options via SWS SSC
  - Programming via short range reflex (off/on)
  - Sensor range (short/medium/long)
  - Max. flow time (1-360 s)
  - Follow-up time (0.6-60 s)
  - Stagnation flush (off/5-600 s, every 1-240 h after last flush/every 1-240 h)
  - Continuous flush for thermal disinfection, with anti-scalding protection (off/15-600 s)
  - Duration of flow (off/15-600 s)
  - Energy saving mode (off/1-254 h after last flush)
  - Cleaning stop (off/60-360 s)
- Setting options via short range reflex
  - Sensor range (short/medium/long)
  - Stagnation flush (off/30 s, every 24 h after last flush/every 24 h)
  - Continuous flush for thermal disinfection, with anti-scalding protection (off/300 s/120 s)
  - Cleaning stop (off/60 s)
- Thermal disinfection: possible, after releasing the temperature lock
- Flow: max. 5 l/min pressure independent
- Flow pressure: 1.0 - 5.0 bar
- Max. Resting pressure: 8 bar
- Max. operating temperature: 70 °C (80 °C for thermal disinfection)
- Material: Housing Brass; Parts in contact with water Plastic
- Surface: Chrome
- Connection: 2x G 3/8 IG
- Certificates: PA-IX 29073/IO, Belgaqua
- Noise class: I
- Flow class: O

**Delivery data**

- Weight: 2,53 kg/Piece
  - Packing unit: 1
- 

**Recommended associated articles**

SSC Bluetooth® module	Article no: 00 916 00 99
Extension cable	Article no: 51 010 00 99 or
Extension cable	Article no: 51 023 00 99 or
Angle valve with regulating function COMFORT with filter	Article no: 05 430 06 99
Wash basin outlet valve OPEN	Article no: 02 002 06 99 or
Wash basin outlet valve PUSH OPEN	Article no: 02 000 06 99 or