

Article number: 01 295 06 99

## Electronic wash basin tap XERIS E HD-K large - high-pressure cold water/pre- mixed water

Infrared sensor-controlled. Battery operation. Suitable for networking with the SCHELL SWS water management system. Configurable via SCHELL Single Control SSC.



### Scope of delivery

- Infrared sensor single-hole tap
  - Infrared sensor electronics, programmable
  - Standpipe extension
  - 6 V axial solenoid valve with pre-filter
  - Flow regulator
  - Connection cable, 350 mm, with 3-pin plug connector, protection class IP65
- 6 V battery compartment, protection class IP65
- 4x AA alkaline battery 1.5 V
- Flexible Clean-Fix S connection hose, G 3/8 IG x 500 mm, with integrated backflow preventer (EN 1717: EB-type) and pre-filter
- Fastening material for wash basin installation

### Technical data

- Setting options via SWS SSC
  - Sensor range (short/medium/long)
  - Programming via short range reflex (off/on)
  - Max. flow time (1-360 s)
  - Follow-up time (0.6-60 s)
  - Stagnation flush (off/5-600 s, every 1-240 h after last flush/every 1-240 h)
  - Continuous flush for thermal disinfection, with anti-scalding protection (off/15-600 s)
  - Duration of flow (off/15-600 s)
  - Energy saving mode (off/1-254 h after last flush)
  - Cleaning stop (off/60-360 s)
- Setting options via short range reflex
  - Sensor range (short/medium/long)
  - Stagnation flush (off/30 s, every 24 h after last flush/every 24 h)
  - Continuous flush for thermal disinfection, with anti-scalding protection (off/300 s/120 s)
  - Cleaning stop (off/60 s)
- Flow: max. 5 l/min pressure independent
- Flow pressure: 1.0 - 5.0 bar
- Max. Resting pressure: 8 bar
- Max. operating temperature: 70 °C (80 °C for thermal disinfection)
- Material: Housing Brass; Parts in contact with water Plastic
- Surface: Chrome
- Certificates: PA-IX 29072/IO, Belgaqua
- Noise class: I
- Flow class: O

### Delivery data

- Weight: 2,57 kg/Piece
- Packing unit: 1

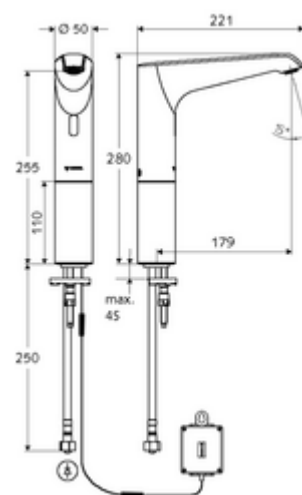

---

### Recommended associated articles

SSC Bluetooth® module	Article no: 00 916 00 99
Extension cable	Article no: 51 010 00 99 or
Extension cable	Article no: 51 023 00 99 or
Angle valve with regulating function COMFORT with filter	Article no: 05 430 06 99